

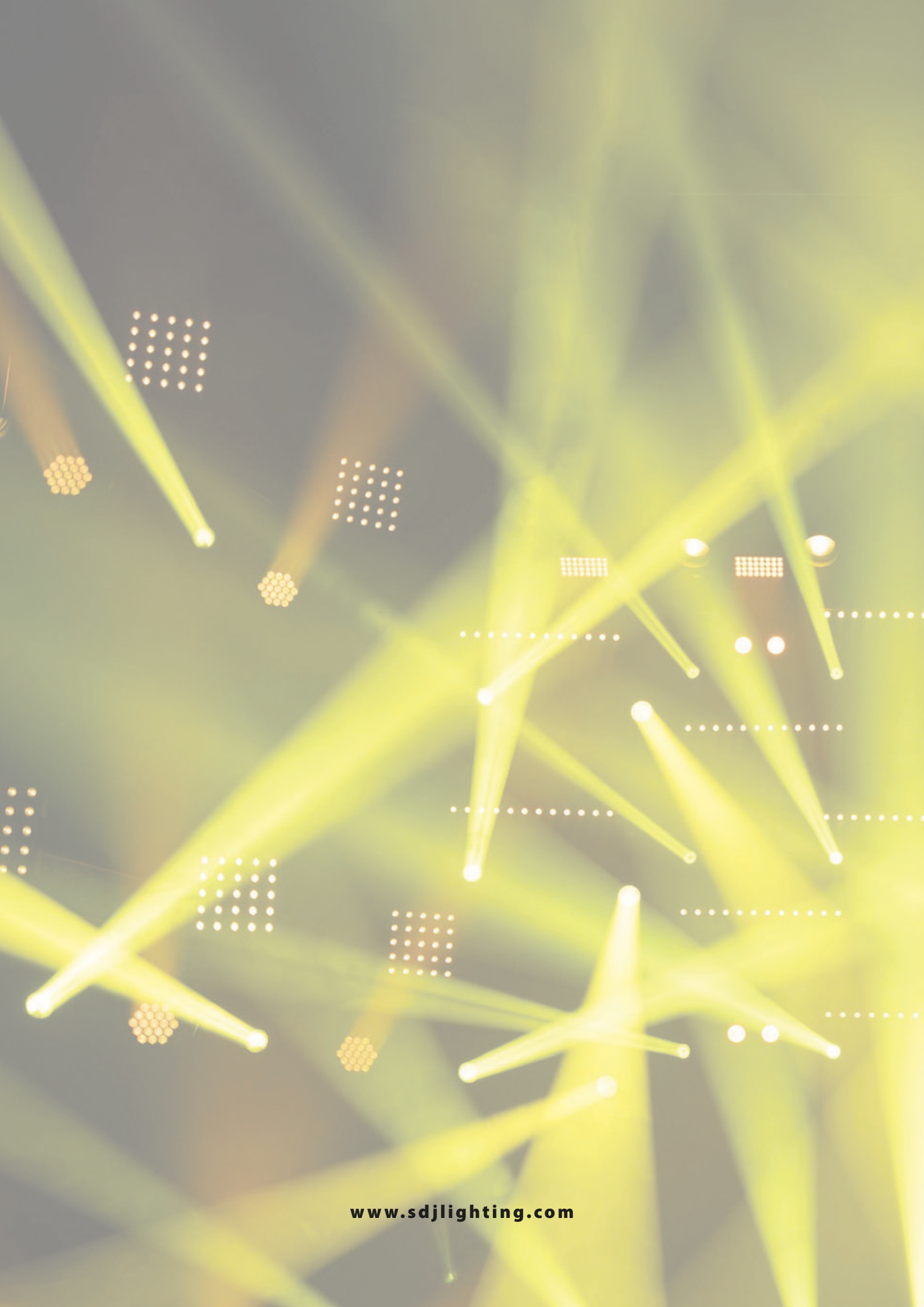

ASDJ



INDEX

4	Moving Heads
11	Indoor Fixtures
21	Battery Projectors
24	Pixel Projectors
29	Led Kits
33	Controllers and Distribution
40	Ambient Effects
46	Accessories
47	Fluids
48	Clamps and Safety Ropes
49	DMX Cables
49	Flightcases



MOVING HEADS



SG JSPOTMINI - PRODUCT CODE

LIGHT SOURCE

- 1x75W white led high brightness
- Color temperature 7500K
- LED lifespan: >50.000h
- LED Refresh frequency: >400Hz flicker-free

OPTIC SYSTEM

- Beam Angle: 14°
- Electronic focus
- Luminous flux: 2700 lux @5mt (14°)

COLOR SYSTEM

- Color wheel with 8 dichroic filters + white

EFFECTS

- Linear dimmer 0 - 100 %
- Electronic strobo, pulse, random
- Gobo wheel: 6 rotating gobos
- Gobo scroll with adjustable speed
- 3-facet rotating prism with adjustable speed
- Color rainbow effect in both directions
- Half color effect
- Frost filter

CONTROL AND PROGRAMMING

- 2 DMX configurations available: 11/13 channels
- Protocol USITT DMX 512
- Master / Slave mode
- Sound mode with adjustable microphone sensitivity
- Auto mode with 9 internal programs selectable from display
- Reset function via DMX

STRUCTURE AND CABINET

- Black metal housing and high resistance plastic material
- Graphic LCD color display
- Pan angle: 360°/540°/630°
- Tilt angle: 90°/180°/270°
- Mounting points: 1 pair of 1/4 turn locks
- Automatic repositioning of Pan&Tilt after accidental movements
- XLR 3-poles DMX IN/OUT connectors
- USB port for optional wireless DMX receiver (order code: SG WECONUSB)
- IP Rating: IP 20
- Forced air cooling system with electronic control

POWER SUPPLY

- Input Voltage: AC~100-240V 50/60Hz
- Switching power supply unit
- Max power: 95W @ 230VAC
- Power IN/OUT Powercon connectors
- Power supply cable 1 mt included

WEIGHT AND DIMENSIONS

- Net weight: 4,5 kg
- Dimensions: 243x304x151 mm

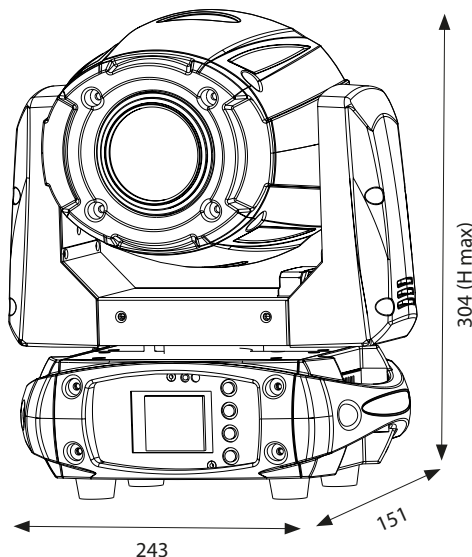

J BEAM MINI

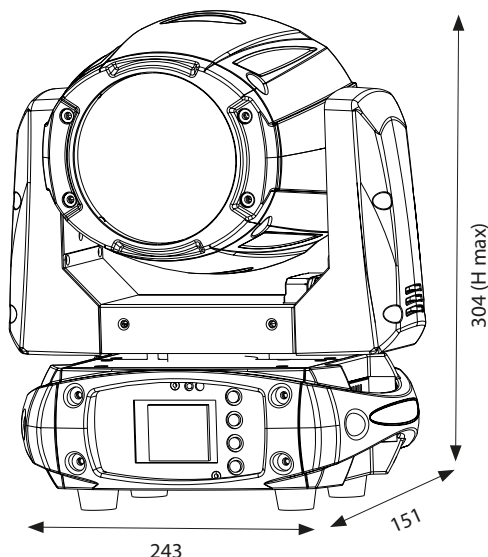

SG JBEAMMINI - PRODUCT CODE

LIGHT SOURCE

- 1x75W white led high brightness
- Color temperature 7500K
- LED lifespan: >50.000h
- LED Refresh frequency: >400Hz flicker-free

OPTIC SYSTEM

- Beam Angle: 3,5°
- Electronic focus
- Luminous flux: 16600 lux @5mt (3,5°)

COLOR SYSTEM

- Color wheel with 12 dichroic filters + white

EFFECTS

- Linear dimmer 0 - 100 %
- Electronic strobo, pulse, random
- Gobo wheel: 17 fixed gobos
- Gobo scroll with adjustable speed
- 8-facet rotating prism with adjustable speed
- Color rainbow effect in both directions
- Half color effect
- Frost filter

CONTROL AND PROGRAMMING

- 2 DMX configurations available: 10/12 channels
- Protocol USITT DMX 512
- Master / Slave mode
- Sound mode with adjustable microphone sensitivity
- Auto mode with 9 internal programs selectable from display
- Reset function via DMX

STRUCTURE AND CABINET

- Black metal housing and high resistance plastic material
- Graphic LCD color display
- Pan angle: 360°/540°/630°
- Tilt angle: 90°/180°/270°
- Mounting points: 1 pair of 1/4 turn locks
- Automatic repositioning of Pan&Tilt after accidental movements
- XLR 3-poles DMX IN/OUT connectors
- USB port for optional wireless DMX receiver (order code: SG WECONUSB)
- IP Rating: IP 20
- Forced air cooling system with electronic control

POWER SUPPLY

- Input Voltage: AC~100-240V 50/60Hz
- Switching power supply unit
- Max power: 95W @ 230VAC
- Power IN/OUT Powercon connectors
- Power supply cable 1 mt included

WEIGHT AND DIMENSIONS

- Net weight: 4,5 kg
- Dimensions: 243x304x151 mm





SG JWASHMINI - PRODUCT CODE

LIGHT SOURCE

- 19x12W led RGBWA-UV Full Color
- LED lifespan: >50.000h
- LED Refresh frequency: >400Hz flicker-free

OPTIC SYSTEM

- Beam Angle: 26°
- Illuminance: 3100 lux @3m (full ON - 26°)

COLOR SYSTEM

- LED source RGBWA-UV Full color
- Virtual linear color wheel 2700° - 8000°K
- Infinite chromatic possibilities

EFFECTS

- Linear dimmer 0 - 100 %
- Electronic strobo, pulse, random
- Control with 3 circular sectors
- Virtual linear color wheel 2700° - 8000°K

CONTROL AND PROGRAMMING

- 3 DMX configurations available: 13/15/17 channels
- Protocol USITT DMX 512
- Master / Slave mode
- Sound mode with adjustable microphone sensitivity
- Auto mode with 9 internal programs selectable from display
- Reset function via DMX

STRUCTURE AND CABINET

- Black metal housing and high resistance plastic material
- Graphic LCD color display
- Pan angle: 360°/540°/630°
- Tilt angle: 90°/180°/270°
- Mounting points: 1 pair of 1/4 turn locks
- Automatic repositioning of Pan&Tilt after accidental movements
- XLR 3-poles DMX IN/OUT connectors
- USB port for optional wireless DMX receiver (order code: SG WECONUSB)
- IP Rating: IP 20
- Forced air cooling system with electronic control

POWER SUPPLY

- Input Voltage: AC~100-240V 50/60Hz
- Switching power supply unit
- Max power: 228W @ 230VAC
- Power IN/OUT Powercon connectors
- Power supply cable 1 mt included

WEIGHT AND DIMENSIONS

- Peso netto: 5 kg
- Dimensioni: 315X355X177 mm

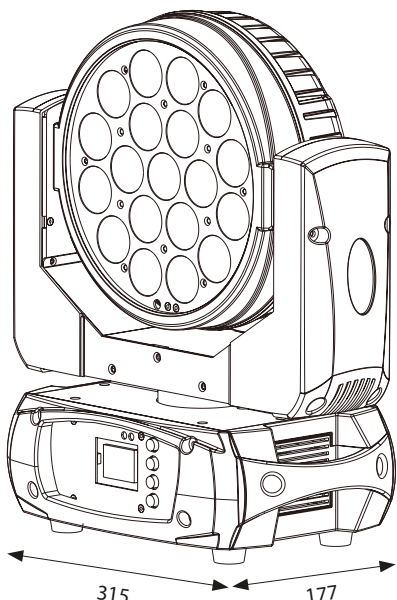

J BEAM 150

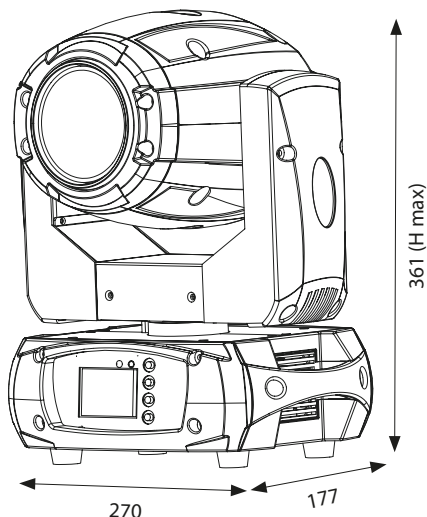

SG JBEAM150 - PRODUCT CODE

LIGHT SOURCE

- 1x150W white led high brightness
- Color temperature 7500K
- LED lifespan: >50.000h
- LED Refresh frequency: >400Hz flicker-free

OPTIC SYSTEM

- Beam Angle: 4°
- Electronic focus
- Luminous flux: 25500 lux @5mt (4°)

COLOR SYSTEM

- Color wheel with 14 dichroic filters + white

EFFECTS

- Linear dimmer 0 - 100 %
- Electronic strobo, pulse, random
- Gobo wheel: 17 fixed gobos
- Gobo scroll with adjustable speed
- 8-facet rotating prism with adjustable speed
- Color rainbow effect
- Half color effect
- Frost filter

CONTROL AND PROGRAMMING

- 2 DMX configurations available: 10/12 channels
- Protocol USITT DMX 512
- Master / Slave mode
- Sound mode with adjustable microphone sensitivity
- Auto mode with 9 internal programs selectable from display
- Reset function via DMX

STRUCTURE AND CABINET

- Black metal housing and high resistance plastic material
- Graphic LCD color display
- Pan angle: 360°/540°/630°
- Tilt angle: 90°/180°/270°
- Mounting points: 1 pair of 1/4 turn locks
- Automatic repositioning of Pan&Tilt after accidental movements
- XLR 3-poles DMX IN/OUT connectors
- USB port for optional wireless DMX receiver (order code: SG WECONUSB)
- IP Rating: IP 20
- Forced air cooling system with electronic control

POWER SUPPLY

- Input Voltage: AC~100-240V 50/60Hz
- Switching power supply unit
- Max power: 180W @ 230VAC
- Power IN/OUT Powercon connectors
- Power supply cable 1 mt included

WEIGHT AND DIMENSIONS

- Net weight: 7,3 kg
- Dimensions: 270x361x177 mm



J BEAM 230



SG JBEAM230 - PRODUCT CODE
SG CASEJBEAM230 - (CASE FOR 2x JBEAM230)
SG JBEAM230KIT - KIT (2x SG JBEAM230 + 1 CASE)

LIGHT SOURCE

- Osram Sirius HRI 231 W
- Lamp lifespan: 2000 h
- Electronic ballast

OPTIC SYSTEM

- Beam Angle: 2,5°
- Electronic focus
- Illuminance: 66.000 lux @ 15 mt

COLOR SYSTEM

- Color wheel with 11 colors + white

EFFECTS

- Linear dimmer 0 - 100 %
- Adjustable strobe effect
- Electronic strobo, pulse, random
- Fixed gobo wheel with 16 gobos and 6 steps "beam reducer"
- Gobo shacking effect
- Gobo scroll effect with adjustable speed
- 16 / 24 facet circular rotating prism with adjustable speed
- Color rainbow effect
- Selectable half color function

CONTROL AND PROGRAMMING

- 3 DMX configurations available: 13 / 15 / 17 channels
- Protocol USITT DMX 512
- Master/Slave mode
- Reset function via DMX
- Built-in analyzer for easy fault finding

STRUCTURE AND CABINET

- Black metal housing and high resistance plastic materials
- LCD color display
- Pan angle: 360° / 540° / 630°
- Tilt angle: 90° / 180° / 270°
- Mounting points: 2 pairs of 1 / 4-turn locks
- Automatic repositioning of Pan and Tilt after accidental movements
- XLR 3-poles DMX IN / OUT connection
- USB port for wireless DMX receiver
- IP rating: IP 20
- Forced air cooling system with electronic control

POWER SUPPLY

- Input Voltage: AC~100 - 240 V, 50/60 Hz
- Switching power supply unit
- Max power: 270 W @ 230 VAC
- Power IN/OUT connection with Seetronic Power Twist
- Power supply cable 1 mt included

WEIGHT AND DIMENSIONS

- Net weight: 12,5 kg
- Dimensions: 338 x 469 x 224 mm

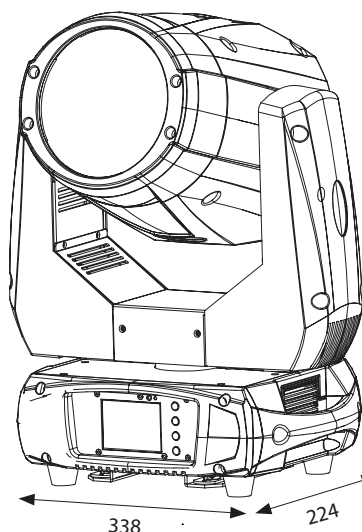

MOVING HEADS

JWASH 400



SG JWASH400 - PRODUCT CODE
SG CASEJWASH400 - (CASE FOR 2x JWASH400)
SG JWASH400KIT - KIT (2x SG JWASH400 + 1x CASE)

LIGHT SOURCE

- 28 x 15 W led RGBW Full Color
- SMD RGB LEDs on the front ring
- LED lifespan: > 50.000 h
- LED refresh frequency: > 400 Hz flicker-free

OPTIC SYSTEM

- Beam Angle: 17° / 32°
- Illuminance: 9224 lux @ 5 m (full ON - 17°)
1417 lux @ 5 m (full ON - 32°)

COLOR SYSTEM

- LED source RGBW Full color
- Infinite chromatic possibilities

EFFECTS

- Linear dimmer 0 - 100 %
- Motorized zoom
- Electronic strobo, pulse, random
- Control with 3 circular sectors
- Front LED ring with programmable static and dynamic effects
- CCT control

CONTROL AND PROGRAMMING

- 3 DMX configurations available: 26 / 31 / 43 channels
- Protocol USITT DMX 512
- Master/Slave mode
- Reset function via DMX
- Built-in analyzer for easy fault finding
- Virtual color wheel with 12 color
- White presets with 9 macros
- Virtual linear color wheel from 2.700 K to 8.000 K

STRUCTURE AND CABINET

- Black metal Housing and plastic materials with high resistance
- LCD color display
- Pan angle: 360° / 540° / 630°
- Tilt angle: 90° / 180° / 270°
- Mounting points: 2 pairs of 1 / 4 turn locks
- Automatic repositioning of Pan and Tilt after accidental movements
- XLR 3-poles DMX IN/OUT connection
- USB port for wireless DMX receiver
- IP Rating: IP 20
- Forced air fan cooling system with electronic control

POWER SUPPLY

- Input Voltage: AC~100 - 240 V 50 / 60 Hz
- Switching power supply unit
- Max power: 390 W @ 230 VAC
- Power IN/OUT connection with Seetronic Power Twist
- Power supply cable 1 mt included

WEIGHT AND DIMENSIONS

- Net weight: 11,5 kg
- Dimensions: 420 x 225 x 250 mm

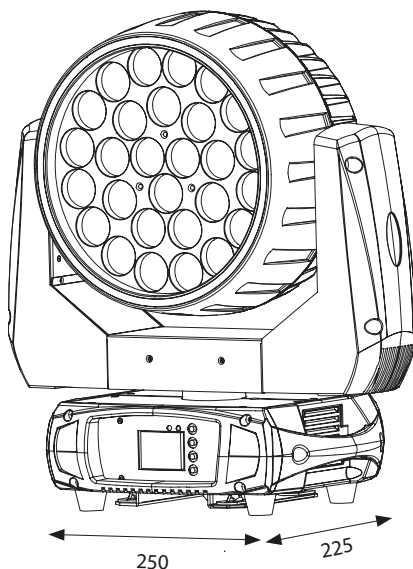

420 (H max)



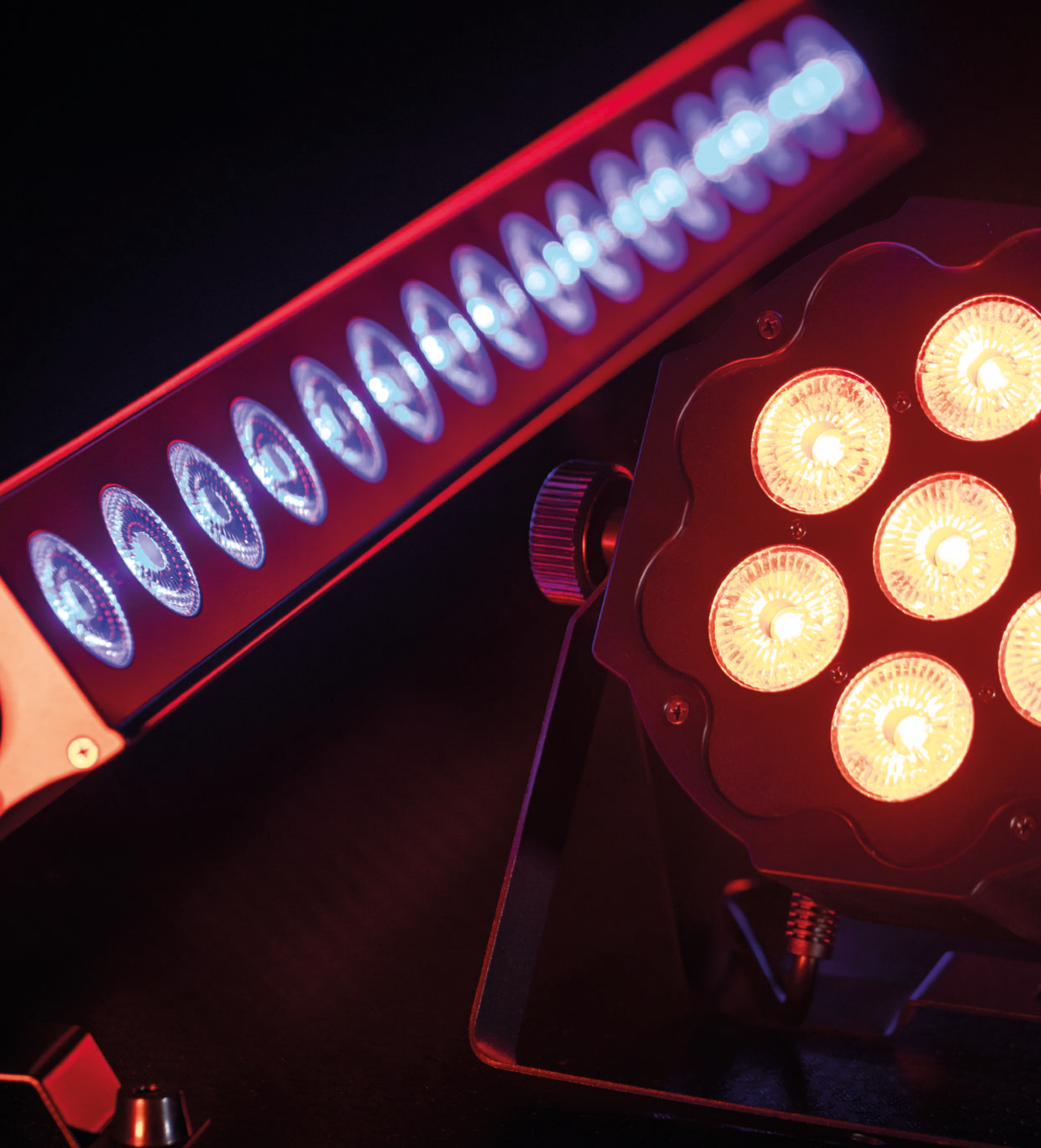

INDOOR FIXTURES

SLIMPAR 7 DL



SG SLIMPAR7DL - PRODUCT CODE

LIGHT SOURCE

- 7x12W led RGBWU Full Color
- LED lifespan: >50.000h
- LED refresh frequency: >400Hz flicker free

OPTIC SYSTEM

- Beam angle: 25°
- Luminous flux: 2290 lux @3mt (25°)

COLOR SYSTEM

- LED source 6 in 1 RGBWU Full Color
- Infinite chromatic possibilities and colour temperature control
- Color temperature control with Amber color
- "Dark Light" technology LED UV (Ultra Violet)
- 2 color macros can be recalled by DMX

EFFECTS

- Linear Dimmer 0-100%
- Electronic strobe: 1-20 flashes/s with adjustable speed

CONTROL AND PROGRAMMING

- 4 DMX configurations available: 1/6/7/10 channels
- USITT DMX 512 protocol
- Master / Slave mode
- Sound mode with adjustable mic sensitivity
- Static color mode with independent adjustment of strobe
- Automatic mode with 2 different programs selectable from the display with independent adjustment of the speed and strobe
- Color mode with 50 different pre-programmed color macros with independent adjustment of the strobe
- IR remote controller included with possibility to recall colors or macros

STRUCTURE AND CABINET

- High resistance ABS housing, black color
- Red LED display
- Mounting points: double adjustable brackets
- "Light up" positioning without brackets
- DMX 3-poles XLR In/Out connectors
- IP rating: IP20
- Forced air fan cooling system

POWER SUPPLY

- Input Voltage: AC~100-240V 50/60Hz
- Switching power supply unit
- Max power: 100W @ 230VAC
- Power In/Out connection with VDE socket
- Power supply cable 1,5 mt included
- Max 6 pcs linkable @240V

WEIGHT AND DIMENSIONS

- Net weight: 2,1 kg
- Dimensions: 257x130x240 mm

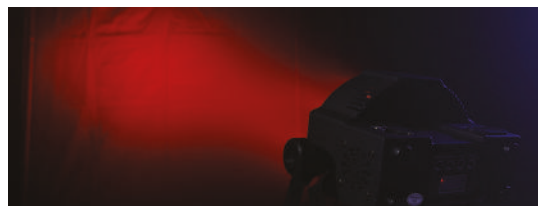
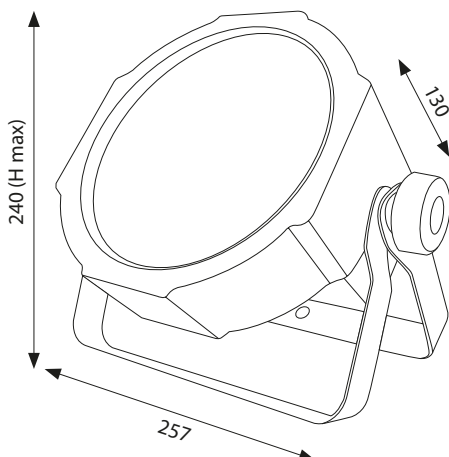

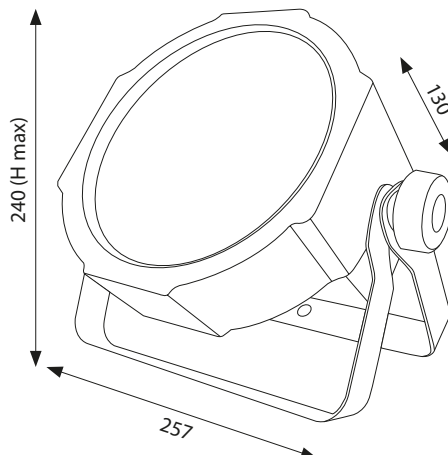

SG SLIMPAR12DL - PRODUCT CODE

LIGHT SOURCE

- 12x12W led RGBWAW Full Color
- LED lifespan: >50.000h
- LED refresh frequency: >400Hz flicker free

OPTIC SYSTEM

- Beam angle: 25°
- Luminous flux: 1210 lux @5mt (25°)

COLOR SYSTEM

- LED source 6 in 1 RGBWAW Full Color
- Infinite chromatic possibilities and colour temperature control
- Color temperature control with Amber color
- "Dark Light" technology LED UV (Ultra Violet)
- 2 color macros can be recalled by DMX

EFFECTS

- Linear Dimmer 0-100%
- Electronic strobe: 1-20 flashes/s with adjustable speed

CONTROL AND PROGRAMMING

- 4 DMX configurations available: 1/6/7/10 channels
- USITT DMX 512 protocol
- Master / Slave mode
- Sound mode with adjustable mic sensitivity
- Static color mode with independent adjustment of strobe
- Automatic mode with 2 different programs selectable from the display with independent adjustment of the speed and strobe
- Color mode with 50 different pre-programmed color macros with independent adjustment of the strobe
- IR remote controller included with possibility to recall colors or macros

STRUCTURE AND CABINET

- High resistance ABS housing, black color
- Red LED display
- Mounting points: double adjustable brackets
- "Light up" positioning without brackets
- DMX 3-poles XLR In/Out connectors
- IP rating: IP20
- Forced air fan cooling system

POWER SUPPLY

- Input Voltage: AC~100-240V 50/60Hz
- Switching power supply unit
- Max power: 160W @ 230VAC
- Power In/Out connection with VDE socket
- Power supply cable 1,5 mt included
- Max 4 pcs linkable @240V

WEIGHT AND DIMENSIONS

- Net weight: 2,1 kg
- Dimensions: 257x130x240 mm

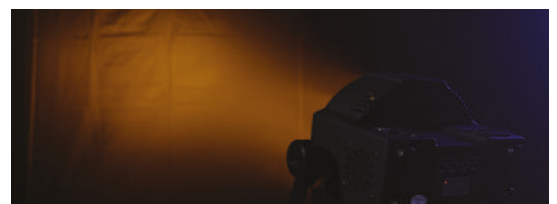

SLIMPAR 12

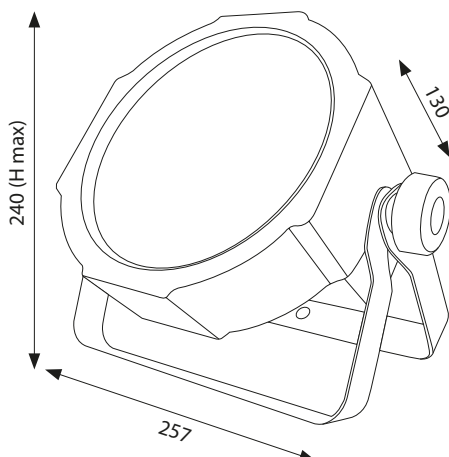

SG SLIMPAR12 - PRODUCT CODE

LIGHT SOURCE

- 12x8W led RGBW Full Color
- LED lifespan: >50.000h
- LED refresh frequency: >400Hz flicker free

OPTIC SYSTEM

- Beam angle: 25°
- Luminous flux: 1060 lux @5mt (25°)

COLOR SYSTEM

- LED source 4 in 1 RGBW Full Color
- Infinite chromatic possibilities and colour temperature control
- 2 color macros can be recalled by DMX

EFFECTS

- Linear Dimmer 0-100%
- Electronic strobe: 1-20 flashes/s with adjustable speed

CONTROL AND PROGRAMMING

- 4 DMX configurations available: 1/4/5/8 channels
- USITT DMX 512 protocol
- Master / Slave mode
- Sound mode with adjustable mic sensitivity
- Static color mode with independent adjustment of strobe
- Automatic mode with 2 different programs selectable from the display with independent adjustment of the speed and strobe
- Color mode with 50 different pre-programmed color macros with independent adjustment of the strobe
- IR remote controller included with possibility to recall colors or macros

STRUCTURE AND CABINET

- High resistance ABS housing, black color
- Red LED display
- Mounting points: double adjustable brackets
- "Light up" positioning without brackets
- DMX 3-poles XLR In/Out connectors
- IP rating: IP20
- Forced air fan cooling system

POWER SUPPLY

- Input Voltage: AC~100-240V 50/60Hz
- Switching power supply unit
- Max power: 110W @ 230VAC
- Power In/Out connection with VDE socket
- Power supply cable 1,5 mt included
- Max 6 pcs linkable @240V

WEIGHT AND DIMENSIONS

- Net weight: 2,1 kg
- Dimensions: 257x130x240 mm

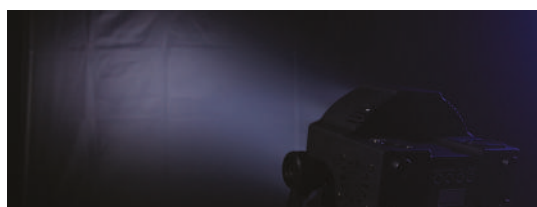
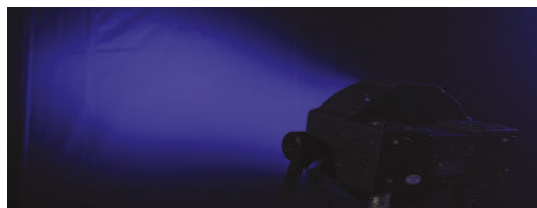

SLIMPAR COB 100



SG SLIMPARCOB100 - PRODUCT CODE

LIGHT SOURCE

- 1x100W RGBW COB led
- LED lifespan: >50.000h
- LED refresh frequency: >400Hz flicker-free

OPTIC SYSTEM

- Beam angle: 50°

COLOR SYSTEM

- RGBW full color mixing
- Infinite chromatic possibilities

EFFECTS

- Fine linear Dimmer 0-100%
- Adjustable strobe 1-10 flash/s

CONTROL AND PROGRAMMING

- 1 DMX configuration available: 7 channels
- Protocol USITT DMX 512
- Master/Slave mode
- Sound Mode
- Automatic mode
- IR remote control

STRUCTURE AND CABINET

- High resistance ABS housing, black color
- Red led display
- Mounting points: double adjustable bracket system
- 3 poles XLR in-out dmx signal connection
- IP20 protection grade
- Forced air fan cooling system

POWER SUPPLY

- Input Voltage: AC~100-240V, 50/60 Hz
- Switching power supply unit
- Max power: 105W @ 230VAC
- Power supply cable included

WEIGHT AND DIMENSIONS

- Net weight: 1,9 kg
- Dimensions: 260x180x240 mm

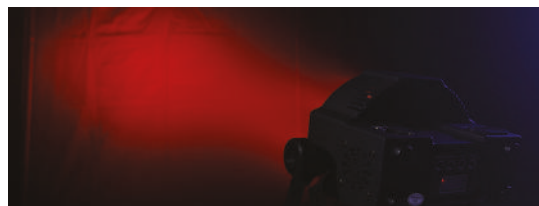
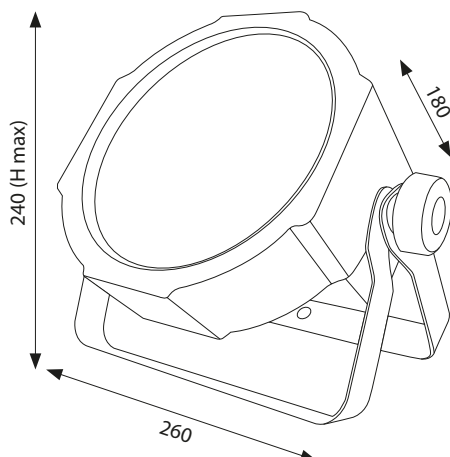

SLIMBAR 16 DL

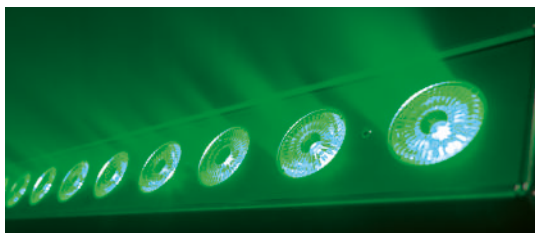
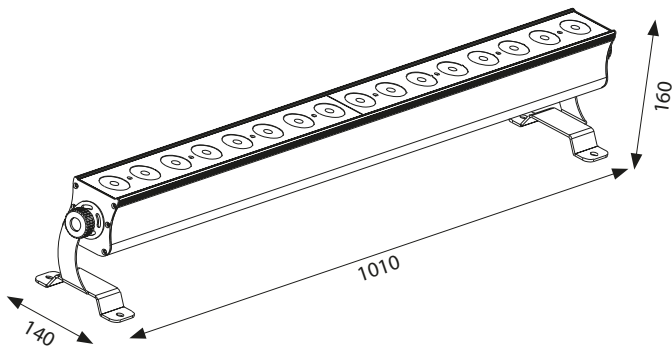

SG SLIMBAR16DL - PRODUCT CODE

LIGHT SOURCE

- 16x12W led RGBWAU Full Color
- LED lifespan: >50.000h
- LED refresh frequency: >400Hz flicker free

OPTIC SYSTEM

- Beam angle: 25°
- Luminous flux: 1390 lux @5mt (25°)

COLOR SYSTEM

- LED source 6 in 1 RGBWAU Full Color
- Infinite chromatic possibilities and colour temperature control
- Color temperature control with Amber color
- "Dark Light" technology LED UV (Ultra Violet)
- 2 color macros can be recalled by DMX

EFFECTS

- Linear Dimmer 0-100%
- Electronic strobe: 1-20 flashes/s with adjustable speed

CONTROL AND PROGRAMMING

- 7 DMX configurations available: 1/6/10/12/28/48/52 channels
- "Double pixel" control system
- USITT DMX 512 protocol
- Master / Slave mode
- Sound mode with adjustable mic sensitivity
- Static color mode with independent adjustment of strobe
- Automatic mode with 12 different programs selectable from the display with independent adjustment of the speed and strobe
- Color mode with 69 different pre-programmed color macros with independent adjustment of the strobe
- IR remote controller included with possibility to recall colors or macros

STRUCTURE AND CABINET

- Aluminum housing, black color
- Blue LCD graphic display
- Mounting points: double adjustable brackets
- Single central bracket for suspension
- "Light up" positioning with angle adjustment
- DMX 3-poles XLR In/Out connectors
- IP rating: IP20
- Forced air fan cooling system with electronic control

POWER SUPPLY

- Input Voltage: AC~100-240V 50/60Hz
- Switching power supply unit
- Max power: 210W @ 230VAC
- Power In/Out connection with powerCON socket
- Power supply cable 1,5 mt included
- Max 4 pcs linkable @240V

WEIGHT AND DIMENSIONS

- Net weight: 5,1 kg
- Dimensions: 1010x140x160 mm

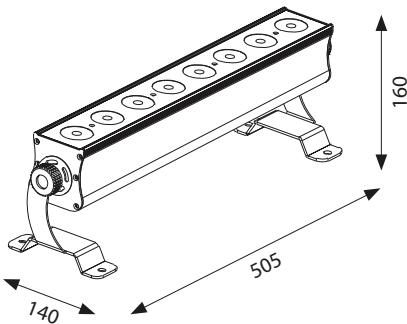

SG SLIMBAR8DL - PRODUCT CODE

LIGHT SOURCE

- 8x12W led RGBWU Full Color
- LED lifespan: >50.000h
- LED refresh frequency: >400Hz flicker free

OPTIC SYSTEM

- Beam angle: 25°
- Luminous flux: 2290 lux @3mt (25°)

COLOR SYSTEM

- LED source 6 in 1 RGBWU Full Color
- Infinite chromatic possibilities and colour temperature control
- Color temperature control with Amber color
- "Dark Light" technology LED UV (Ultra Violet)
- 2 color macros can be recalled by DMX

EFFECTS

- Linear Dimmer 0-100%
- Electronic strobe: 1-20 flashes/s with adjustable speed

CONTROL AND PROGRAMMING

- 6 DMX configurations available: 1/6/10/12/24/28 channels
- "Double pixel" control system
- USITT DMX 512 protocol
- Master / Slave mode
- Sound mode with adjustable mic sensitivity
- Static color mode with independent adjustment of strobe
- Automatic mode with 12 different programs selectable from the display with independent adjustment of the speed and strobe
- Color mode with 69 different pre-programmed color macros with independent adjustment of the strobe
- IR remote controller included with possibility to recall colors or macros

STRUCTURE AND CABINET

- Aluminum housing, black color
- Blue LCD graphic display
- Mounting points: double adjustable brackets
- Single central bracket for suspension
- "Light up" positioning with angle adjustment
- DMX 3-poles XLR In/Out connectors
- IP rating: IP20
- Forced air fan cooling system with electronic control

POWER SUPPLY

- Input Voltage: AC~100-240V 50/60Hz
- Switching power supply unit
- Max power: 110W @ 230VAC
- Power In/Out connection with powerCON socket
- Power supply cable 1,5 mt included
- Max 6 pcs linkable @240V

WEIGHT AND DIMENSIONS

- Net weight: 3,6 kg
- Dimensions: 505x140x160 mm

INDOOR FIXTURES

SLIMBAR 12P

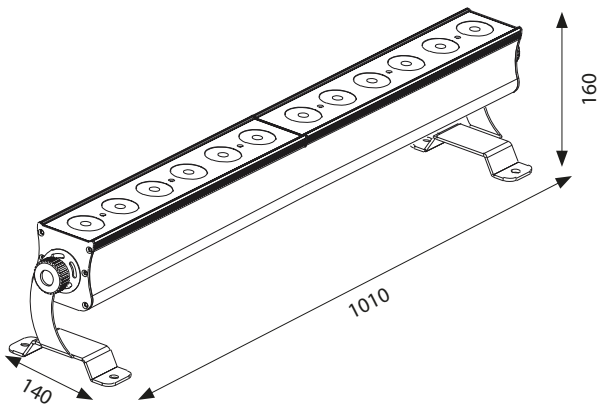

SG SLIMBAR12P - PRODUCT CODE

LIGHT SOURCE

- 12x15W led RGBW Full Color
- LED lifespan: >50.000h
- LED refresh frequency: >400Hz flicker free

OPTIC SYSTEM

- Beam angle: 10° x 45°
- Luminous flux: 1420 lux @5mt

COLOR SYSTEM

- LED source 4 in 1 RGBW Full Color
- Infinite chromatic possibilities and colour temperature control

EFFECTS

- Linear Dimmer 0-100%
- Electronic strobe: 1-20 flashes/s with adjustable speed
- Color macros selectable by DMX
- Single pixel control

CONTROL AND PROGRAMMING

- 7 DMX configurations available in: 3/4/5/8/10/48/52 channels
- USITT DMX 512 protocol
- Master / Slave mode
- Sound mode with adjustable mic sensitivity
- Static color mode with independent adjustment of strobe
- Automatic mode with 12 different programs selectable from the display with independent adjustment of the speed and strobe
- Color mode with 51 different pre-programmed color macros with independent adjustment of the strobe
- IR remote controller included with possibility to select colors or macros (Included)

STRUCTURE AND CABINET

- Aluminum housing, black color
- LCD graphic color display
- Mounting points: double adjustable brackets
- Single central bracket for suspension
- "Light up" positioning with angle adjustment
- DMX 3-poles XLR In/Out connectors
- IP rating: IP20
- Forced air fan cooling system with electronic control

POWER SUPPLY

- Input Voltage: AC~100-240V 50/60Hz
- Switching power supply unit
- Max power: 190W @ 230VAC
- Power In/Out connection with powerCON socket
- Power supply cable 1,5 mt included
- Max 4 pcs linkable @240V

WEIGHT AND DIMENSIONS

- Net weight: 5,1 kg
- Dimensions: 1010x140x160 mm



SG HTZLEDPANELTW - PRODUCT CODE

LIGHT SOURCE

- 864 Warm White LEDs SMD + 864 Cold white LEDs SMD
- CRI ≥ 95 Ra
- LED lifespan: >50.000h
- LED refresh frequency: adjustable from 600 to 8000 Hz. Anti flicker

OPTIC SYSTEM

- Beam angle: 120°
- Matrix compound optical system on the front panel

EFFECTS

- Linear Dimmer 0-100%
- Adjustable CCT from 3200K to 6000K
- Independent adjustment of Dimmer and CCT with knobs
- Adjustable Strobe
- 3 Dimmer curves available (Linear – S-Curve – Log)
- 1 fade dimmer selectable

CONTROL AND PROGRAMMING

- 3 DMX configuration available: 2/3/5 channels
- Protocol USITT DMX 512

STRUCTURE AND CABINET

- Black aluminum and metal housing
- Blue LCD graphic display
- 3 poles XLR in/out dmx signal connections
- Convection cooling system without fans
- Barndoor included
- Soft bag included

POWER SUPPLY

- Input Voltage: AC~100-240V, 50/60 Hz
- Switching power supply unit
- Max power: 200W @ 230VAC
- IN/OUT Power connection with PowerCON
- Power supply cable included

WEIGHT AND DIMENSIONS

- Net weight: 7,2 kg
- Dimensions: 610x440x140 mm

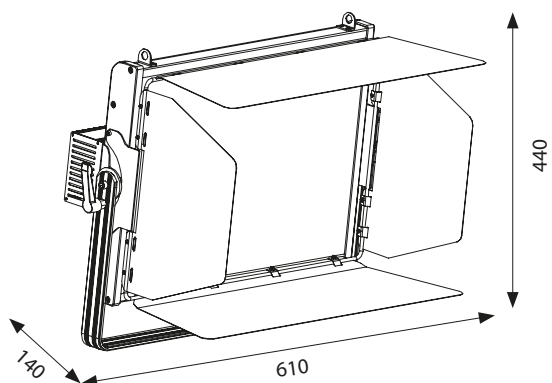



BATTERY PROJECTORS

BATTERY PROJECTORS

J BAR 8 BAT

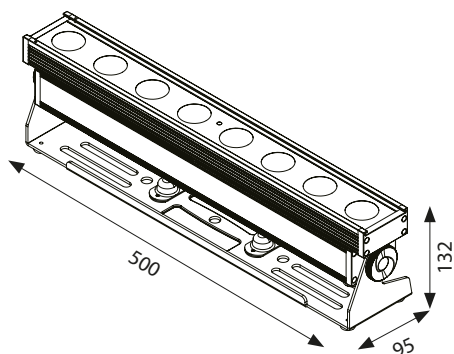

SG JBAR8BAT - PRODUCT CODE

SG CASEJBAR8BAT - (CASE FOR 6x JBAR8BAT + CHARGING SYSTEM)

LIGHT SOURCE

- 8x10W led RGBW Full Color
- LED lifespan: > 50.000h
- LED refresh frequency: 600 Hz flicker-free

OPTIC SYSTEM

- Beam Angle: 25°

COLOR SYSTEM

- LED source RGBW Full color
- Infinite chromatic possibilities
- Effects Linear dimmer 0-100%
- Adjustable strobe effect
- Pixel control

CONTROL AND PROGRAMMING

- 6 DMX configurations available: 3/4/6/13/32/41 channels
- Protocol USITT DMX 512
- Built-in wireless DMX transceiver
- Master/Slave mode
- Static Color mode
- Auto mode with 13 programs selectable from the display, with speed adjustment
- Color mode with 50 color macros and 11 white macros
- Color calibration system
- Power management system
- 4 different dimming curves available

STRUCTURE AND CABINET

- High corrosion die cast aluminum housing
- Color LCD display
- Front tempered glass
- "Light up" positioning with adjustable angle +100°/-80°
- IP65 rating
- Convection cooling system without fans

POWER SUPPLY

- Input Voltage: 15VDC 3A
- Switching power supply unit
- Rechargeable internal Li-Ion battery: 10,8VDC 10000mAh
- Runtime battery: ~ 3 hrs (full ON – High power mode)
- Runtime battery: ~ 11 hrs (Color change – High power mode)
- Charging cycle: ~ 6 hrs (Projector turned off)
- Max power: 65W
- External power supply included: IN AC~100-240V, 50/60 Hz – OUT 15VDC 3A

WEIGHT AND DIMENSIONS

- Net weight: 3,5 kg
- Dimensions: 500x95x132(h) mm

BATTERY PROJECTORS

JTUBE 1X

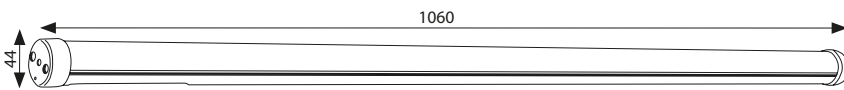
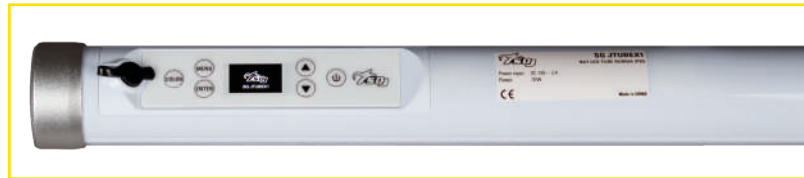

SG JTUBE1X - PRODUCT CODE

LIGHT SOURCE

- 320x0,5W LED RGB+Amber+Mint (64R – 64G – 64B – 64A – 64M)
- LED lifespan: > 50.000h
- LED refresh frequency: 15 KHz flicker-free

OPTIC SYSTEM

- Beam Angle: 135°x115°

COLOR SYSTEM

- LED source RGB+Amber+Mint (64R – 64G – 64B – 64A – 64M)
- Infinite chromatic possibilities

EFFECTS

- Linear dimmer 0-100%
- Adjustable strobe effect
- Pixel control

CONTROL AND PROGRAMMING

- 7 DMX configurations available: 3/4/6/13/48/80/88 channels
- Protocol USITT DMX 512
- Built-in wireless DMX transceiver
- Master/Slave mode
- Static Color mode
- Auto mode with 30 programs selectable from the display, with speed adjustment
- Color mode with 101 color macros and 112 white macros
- Color calibration system
- Power management system
- 4 different dimming curves available

STRUCTURE AND CABINET

- Die cast aluminum housing
- Color LCD display
- White plexiglass
- IP65 rating

POWER SUPPLY

- Input Voltage: 18VDC – 5A
- Switching power supply unit
- Rechargeable internal Li-Ion battery: 14,4VDC 6400mAh
- Runtime battery: ~ 1h:45m (full ON – Boost power mode)
- Runtime battery: ~ 3h (Color change – Boost power mode)
- Charging cycle: ~ 6 hrs (Projector turned off)
- Max power: 70W
- External power supply included IN AC 100-240V, 50/60 Hz – OUT 18VDC – 5A

WEIGHT AND DIMENSIONS

- Net weight: 1,35 kg
- Dimensions: 1060xØ44 mm

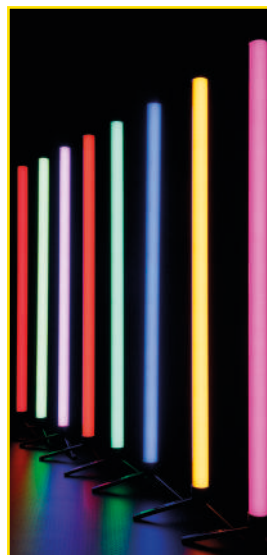

SG JTUBE1XSTAND



SG JTUBE1XBAG CHARGING SYSTEM INCLUDED



SG JTUBE1XCON1



SG JTUBE1XCON2



SG JTUBE1XCON3



SG JTUBE1XCLAMP

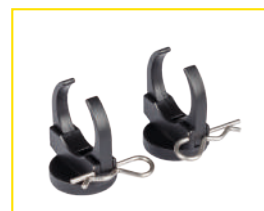

SG JTUBE1XCLAMPT





PIXEL PROJECTORS

PIXEL PROJECTORS

QPIX BAR 50 CM

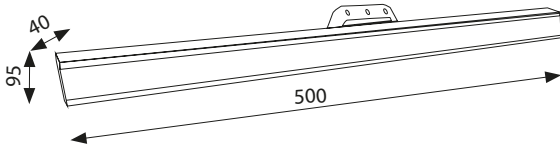
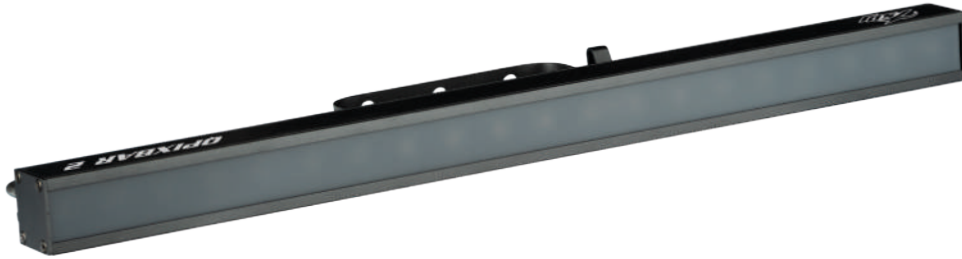

SG QPIXBAR2 - PRODUCT CODE

SG CASEQPIXBAR - CASE (32X SG QPIXBAR2)

SG QPIXBARRWD2 - QPIX BAR ROUND WHITE DIFFUSER LENGTH 50C

SG QPIXBARBS - QPIX BAR FLOOR BASE FOR 2 VERTICAL BARS

SG QPIXBARCKV - QPIX BAR CONNECTION KIT VARIABLE 2 WAYS

SG QPIXBARCK2 - QPIX BAR CONNECTION KIT 2 WAYS 90°

SG QPIXBARCK3 - QPIX BAR CONNECTION KIT 3 WAYS T

SG QPIXBARCK4 - QPIX BAR CONNECTION KIT 4 WAYS

LIGHT SOURCE

- 20 SMD5050 led RGB high efficiency (for each QPix Bar)
- Led refresh frequency >400Hz flicker free

OPTIC SYSTEM

- Viewing angle 120° x 120°
- Flat smoked diffuser (flat white diffuser included)
- Pitch 25 mm

COLOR SYSTEM

- RGB led source

EFFECTS

- Control pixel to pixel
- Linear dimmer
- Electronic strobe
- Color macro and pixel macro can be recalled by DMX

CONTROL AND PROGRAMMING

- 5 different DMX configuration available 7/16/48/82/480
- Artnet configuration available 4x480
- Proprietary control signal between QPix Bar
- DMX/Artnet control by QPix Bar BOX (sold separately)
- Signal cable CAT 6 UTP AVG24
- Each QPix Bar Box control 16 pcs of QPix Bar divided into 4 outputs
- Master/Slave mode

STRUCTURE AND CABINET

- Diecast aluminium housing black color
- Mounting points: single metal bracket for suspension
- 1 linear connection KIT (included)
- 3 different connection KIT multi ways (sold separately)
- RJ45 IN/OUT connections on the QPix Bar
- 3/5 poles XLR IN/OUT on the QPix Bar BOX
- RJ45 EtherCON data connectors IN/OUT on the QPix Bar BOX
- 4 outputs RJ45 EtherCON connections on the QPix Bar BOX
- IP rating 20

POWER SUPPLY

- QPix Bar is powered by QPix Bar BOX
- Maximum power 400W for the QPix Bar BOX (full power maximum 16 pcs of 100cm led bar or 32 pcs of 50cm led bar)
- IN/OUT power connection with PowerCON on the QPix Bar Box

WEIGHT AND DIMENSIONS

- QPix Bar weight: 0,8kg
- QPix Bar BOX: 4kg
- QPix Bar sizes: 500x40x95 mm
- QPix Bar BOX sizes: 290x205x85 mm

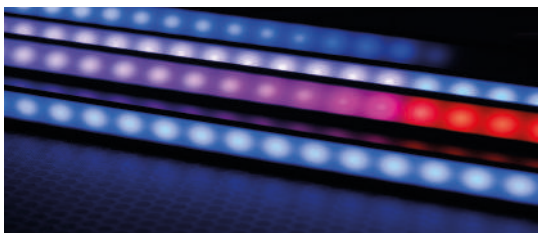
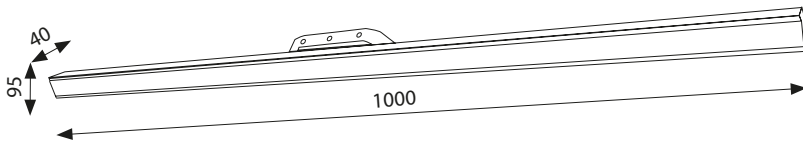

SG QPIXBARV2 - PRODUCT CODE

SG CASEQPIXBAR - CASE (16X SG QPIXBAR)

SG QPIXBARWD - QPIX BAR ROUND WHITE DIFFUSER

SG QPIXBARBS - QPIX BAR FLOOR BASE FOR 2 VERTICAL BARS

SG QPIXBARCKV - QPIX BAR CONNECTION KIT VARIABLE 2 WAYS

SG QPIXBARCK2 - QPIX BAR CONNECTION KIT 2 WAYS 90°

SG QPIXBARCK3 - QPIX BAR CONNECTION KIT 3 WAYS T

SG QPIXBARCK4 - QPIX BAR CONNECTION KIT 4 WAYS

LIGHT SOURCE

- 40 SMD5050 led RGB high efficiency (for each QPix Bar)
- Led refresh frequency >400Hz flicker free

OPTIC SYSTEM

- Viewing angle 120° x 120°
- Flat smoked diffuser (flat white diffuser included)
- Pitch 25 mm

COLOR SYSTEM

- RGB led source

EFFECTS

- Control pixel to pixel
- Linear dimmer
- Electronic strobe
- Color macro and pixel macro can be recalled by DMX

CONTROL AND PROGRAMMING

- 5 different DMX configuration available 7/16/48/82/480
- Artnet configuration available 4x480
- Proprietary control signal between QPix Bar
- DMX/Artnet control by QPix Bar BOX (sold separately)
- Signal cable CAT 6 UTP AVG24
- Each QPix Bar Box control 16 pcs of QPix Bar divided into 4 outputs
- Master/Slave mode

STRUCTURE AND CABINET

- Diecast aluminium housing black color
- Mounting points: single metal bracket for suspension
- 1 linear connection KIT (included)
- 3 different connection KIT multi ways (sold separately)
- RJ45 IN/OUT connections on the QPix Bar
- 3/5 poles XLR IN/OUT on the QPix Bar BOX
- RJ45 EtherCON data connectors IN/OUT on the QPix Bar BOX
- 4 outputs RJ45 EtherCON connections on the QPix Bar BOX
- IP rating 20

POWER SUPPLY

- QPix Bar is powered by QPix Bar BOX
- Maximum power 400W for the QPix Bar BOX (full power maximum 16 pcs of 100cm led bar or 32 pcs of 50cm led bar)
- IN/OUT power connection with PowerCON on the QPix Bar BOX

WEIGHT AND DIMENSIONS

- QPix Bar weight: 1,2kg
- QPix Bar BOX: 4kg
- QPix Bar sizes: 1000x40x95 mm
- QPix Bar BOX sizes: 290x205x85 mm

QPIX BAR CONTROL BOX



SG QPIXBARBOXV2 - PRODUCT CODE

CONTROL AND PROGRAMMING

- 5 different DMX configuration available 7/16/48/82/480
- Artnet configuration available 4x480
- Proprietary control signal between QPix Bar
- Master/Slave mode
- DMX/Artnet control by QPix Bar BOX (sold separately)
- Signal cable CAT 6 UTP AVG24
- Each QPix Bar Box control 16 pcs of QPix Bar 100 cm divided into 4 outputs
- Each QPix Bar Box control 32 pcs of QPix Bar 50 cm divided into 4 outputs

STRUCTURE AND CABINET

- 3/5 poles XLR IN/OUT on the QPix Bar BOX
- RJ45 EtherCON data connectors IN/OUT on the QPix Bar BOX
- 4 outputs RJ45 EtherCON connections on the QPix Bar BOX
- IP rating 20

POWER SUPPLY

- QPix Bar is powered by QPix Bar BOX
- Maximum power 400W for the QPix Bar BOX (full power maximum 16 pcs of 100cm led bar or 32 pcs of 50cm led bar)
- IN/OUT power connection with PowerCON on the QPix Bar Box

WEIGHT AND DIMENSIONS

- QPix Bar weight: 1,2kg
- QPix Bar BOX: 4kg
- QPix Bar sizes: 100x40x95 mm
- QPix Bar BOX sizes: 290x205x85 mm

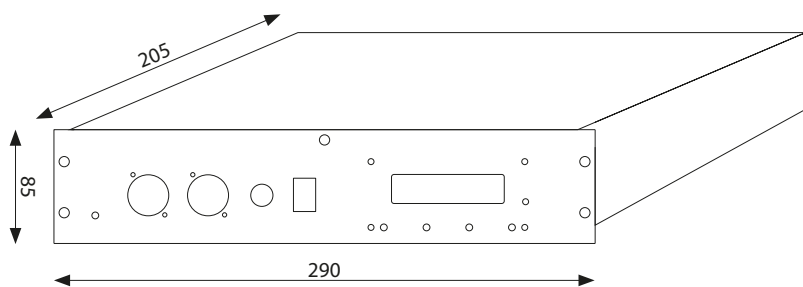



SG PIX.I5W - PRODUCT CODE
SG CASEPIX.I5 - CASE (6x SGPIX.I5W)

LIGHT SOURCE

- 25x3W CREE XPE led Warm White 2800K
- LED lifespan: >50.000h
- LED refresh frequency: >400Hz flicker free

OPTIC SYSTEM

- Beam angle: 5°
- Luminous flux: 7750 lux @5mt (15°)
- DC (dark cover) optical insulation system

COLOR SYSTEM

- LED source CREE Warm White 2800K

EFFECTS

- Linear Dimmer 0-100%
- Electronic strobe: 1-20 flashes/s with adjustable speed
- Color macros and pixel can be recalled by DMX

CONTROL AND PROGRAMMING

- 4 DMX configurations available: 1/2/6/25 channels
- 3 selectable dimmer curves
- Single pixel control
- USITT DMX 512 protocol
- Master / Slave mode
- Sound mode with adjustable mic sensitivity
- Static color mode with independent adjustment of strobe
- Automatic mode with 120 different programs selectable from the display with independent adjustment of the speed

STRUCTURE AND CABINET

- Aluminum housing, black color
- LCD graphic color display
- Mounting points: double central adjustable bracket
- Specific hardware for connection between panels
- DMX 3-poles XLR In/Out connectors
- IP rating: IP20
- Fan cooling system without fans

POWER SUPPLY

- Input Voltage: AC~100-240V 50/60Hz
- Switching power supply unit
- Max power: 80W @ 230VAC
- Power In/Out connection with powerCON socket
- Power supply cable 1,5 mt included
- Max 8 pcs linkable @240V

WEIGHT AND DIMENSIONS

- Net weight: 6,8 kg
- Dimensions: 399x113x399 mm

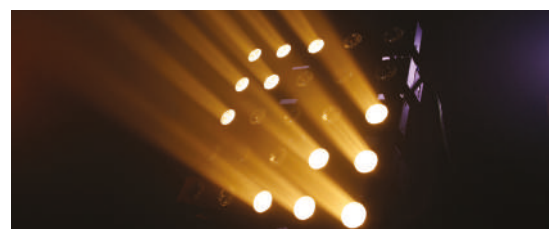
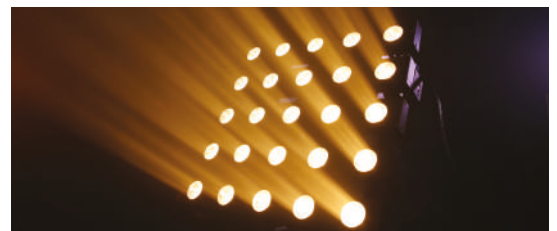
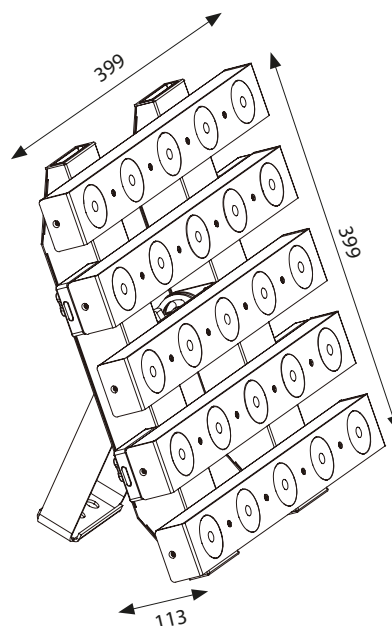

JPIX 40

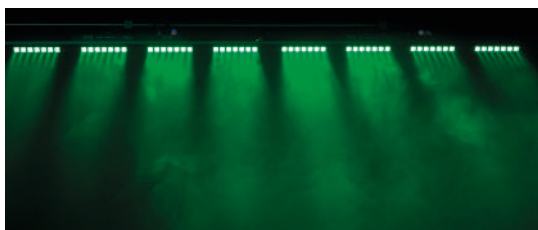
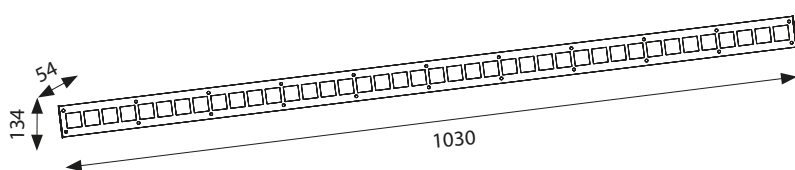

SG PIX40 - PRODUCT CODE

LIGHT SOURCE

- 40x3W led RGB Full Color
- LED lifespan: > 50.000h
- LED refresh frequency: > from 600 Hz to 15 KHz flicker-free

OPTIC SYSTEM

- Beam Angle: 8°

COLOR SYSTEM

- LED source RGB Full color
- Infinite chromatic possibilities
- Effects
- Linear dimmer 0-100%
- Adjustable strobe effect
- Pixel control

CONTROL AND PROGRAMMING

- 13 DMX configurations available: 3/4/6/7/8/12/13/24/25/60/61 /120/121 channels
- Protocol USITT DMX 512
- Master/Slave mode
- Static Color mode
- Auto mode with 45 programs selectable from the display, with speed adjustment
- Auto mode with 23 programs selectable from the display, with color settings

STRUCTURE AND CABINET

- Aluminum housing, black color
- Red LED display
- IP20 rating
- DMX 3-poles XLR IN/OUT connectors
- USB port for optional wireless DMX receiver (order code: SG WECONUSB)
- Forced air fan cooling system

POWER SUPPLY

- Input Voltage: AC~100-240V, 50/60 Hz
- Switching power supply unit
- Max power: 100W @ 230VAC
- Power Out Max 5A
- Powercon Connectors IN/OUT

WEIGHT AND DIMENSIONS

- Net weight: 2 kg
- Dimensions: 1030x54x134(h) mm



LED KITS

LED KIT 3C



SG LEDKITHP3C - PRODUCT CODE

LIGHT SOURCE

- Kit 4 projectors 3x6W led RGBW Full Color
- LED lifespan: > 50.000h

OPTIC SYSTEM

- Beam Angle: 25°

COLOR SYSTEM

- Led Source 4 in 1 RGBW Full Color
- Infinite chromatic possibilities

EFFECTS

- Linear dimmer 0-100%
- Adjustable strobe effect
- Auto mode can be recalled by DMX

CONTROL AND PROGRAMMING

- 5 DMX configurations available: 4/6/10/16/18 channels
- Each projector can be controlled independently via DMX
- USITT DMX 512 protocol
- Master/Slave mode
- Sound mode with adjustable microphone sensitivity
- Automatic mode with 6 different programs selectable from the display or footswitch, with adjustment of the speed
- Color mode with 9 different pre-programmed color macros
- Footswitch control included: Blackout, Sound, Auto, Freeze

STRUCTURE AND CABINET

- Metal housing, black color
- Red LED display
- Mounting points: double adjustable brackets
- "Light up" positioning
- DMX 3-poles XLR In/Out connectors
- IP rating: IP20
- Stand max. H 2200
- Soft bag for bar for transport included

POWER SUPPLY

- Input Voltage: AC~100-240V, 50/60 Hz
- Switching power supply unit
- Max power: 80W @ 230VAC
- Power supply cable included

WEIGHT AND DIMENSIONS

- Bar net weight: 5,8 kg
- Stand net weight: 2,8 kg
- Bar Dimensions: 950x90x230 mm

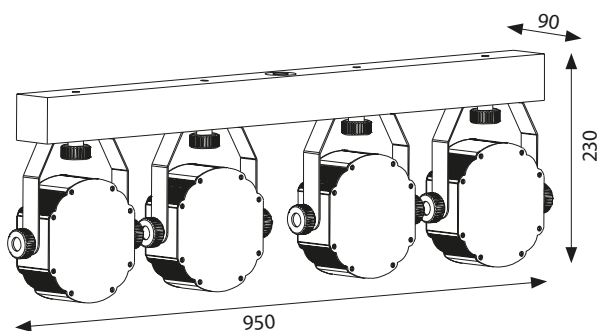

LED KIT 7 BATTERY



SG LEDKITHP7BAT - PRODUCT CODE

LIGHT SOURCE

- Kit 4 projectors 7x10W led RGBW Full Color
- LED lifespan: > 50.000h

OPTIC SYSTEM

- Beam Angle: 25°

COLOR SYSTEM

- Led Source 4 in 1 RGBW Full Color
- Infinite chromatic possibilities

EFFECTS

- Linear dimmer 0-100%
- Adjustable strobe effect
- Auto mode can be recalled by DMX

CONTROL AND PROGRAMMING

- 7 DMX configurations available: 4/5/6/9/10/16/20 channels
- Each projector can be controlled independently via DMX
- USITT DMX 512 protocol
- Master/Slave mode
- Sound mode with adjustable microphone sensitivity
- Automatic mode with 6 different programs selectable from the display or footswitch, with adjustment of the speed
- Color mode with 9 different pre-programmed color macros
- Wireless battery footswitch: Blackout, Sound, Auto, Freeze (included)

STRUCTURE AND CABINET

- Metal housing, black color
- Red LED display
- Mounting points: double adjustable brackets
- "Light up" positioning
- DMX 3-poles XLR In/Out connectors
- IP rating: IP20
- Stand max. H 2800
- Soft bag for bar for transport included

POWER SUPPLY

- Input Voltage: AC~100-240V, 50/60 Hz
- Switching power supply unit
- Max power: 300W @ 230VAC
- Internal Li – ion rechargeable battery
- Runtime battery: ~ 6 hrs (full ON)
- Charging cycle: ~ 5 hrs (led blackout when charging)
- Power supply cable included

WEIGHT AND DIMENSIONS

- Bar net weight: 9,6 kg
- Stand net weight: 4,5 kg
- Bar Dimensions: 1180x90x270 mm

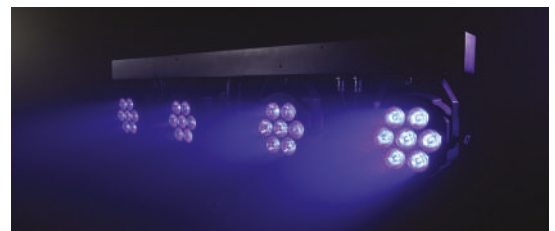
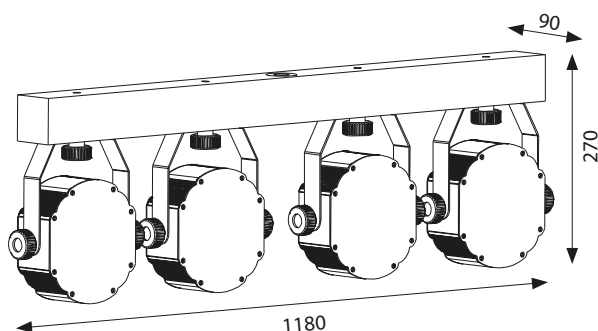

LED KIT 7

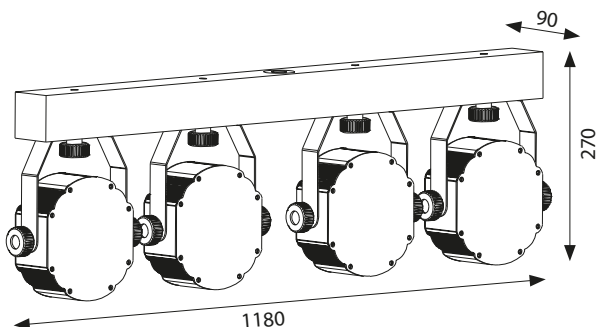

SG LEDKITHP7 - PRODUCT CODE

LIGHT SOURCE

- Kit 4 projectors 7x10W led RGBW Full Color
- LED lifespan: >50.000h
- LED refresh frequency: >400Hz flicker free

OPTIC SYSTEM

- Beam angle: 25°

COLOR SYSTEM

- LED source 4 in 1 RGBW Full Color
- Infinite chromatic possibilities and colour temperature control

EFFECTS

- Linear Dimmer 0-100%
- Electronic strobe: 1-20 flashes/s with adjustable speed
- 1 Auto mode can be recalled by DMX

CONTROL AND PROGRAMMING

- 5 DMX configurations available: 4/6/10/16/18 channels
- Each projector can be controlled independently
- USITT DMX 512 protocol
- Master / Slave mode
- Sound mode with adjustable mic sensitivity
- Automatic mode with 6 different programs selectable from the display or footswitch with independent adjustment of the speed
- Color mode with 9 different pre-programmed color macros + 1 adjustable macro
- Footswitch control included: Blackout, Sound, Auto, Freeze

STRUCTURE AND CABINET

- Metal housing, black color
- Red LED display
- Mounting points: double adjustable brackets
- "Light up" positioning
- DMX 3-poles XLR In/Out connectors
- IP rating: IP20
- Stand max. H 2800 mm with bag for transport included
- Semi rigid bag for bar transport included

POWER SUPPLY

- Input Voltage: AC~100-240V 50/60Hz
- Switching power supply unit
- Max power: 300W @ 230VAC
- Power In/Out connection with VDE socket
- Power supply cable 1,5 mt included
- Max 4 pcs linkable @240V

WEIGHT AND DIMENSIONS

- Bar Net weight: 8,5 kg
- Stand Net weight: 4,5 kg
- Bar Dimensions: 1180x90x270 mm

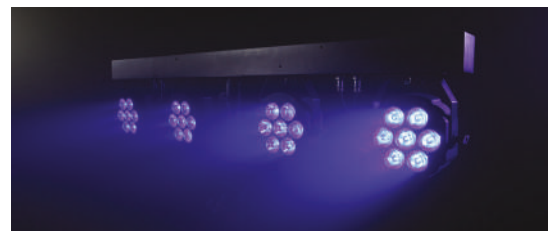

A close-up, high-angle photograph of a vintage synthesizer control panel. The panel is dark with yellow and white markings. It features several vertical sliders with numbered scales (0, 2, 4, 6, 8, 10) and several rotary knobs with textured tops. A central horizontal track has a dashed line with numbered boxes (8, 9, 10, 11, 12) and small colored beads (green, yellow) placed along it. Various buttons are scattered across the panel, some with labels like 'BEAT REV', 'DARK', 'CHASE', 'A DOUBLE', '1-24/48 SINGI', 'PARK A', 'DOWN', 'MO', 'LAS', and 'SET B'. The overall lighting is warm and focused on the central track.

CONTROLLERS AND DISTRIBUTION

CONTROLLERS AND DISTRIBUTION

FASTER 192P

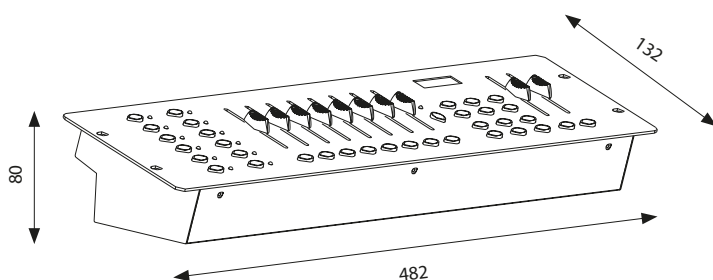
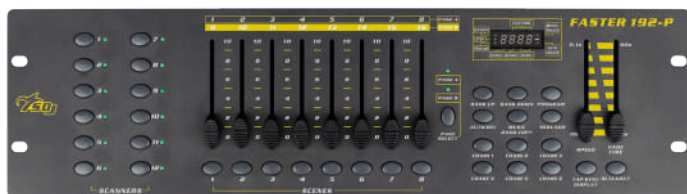

SG FASTER192P - PRODUCT CODE

TECHNICAL DATA

- DMX controller
- Max 12 projectors, 16 channel each
- Total 192 DMX channels
- 8 sliders for control (page A/B)
- 8 programmable scenes in 23 banks
- 6 chases
- Auto mode
- Sound mode (internal microphone)

POWER SUPPLY

- Input Voltage: DC 12V, 300 mA min
- External adapter included: AC~100-240V, 50/60Hz

WEIGHT AND DIMENSIONS

- Net weight: 2,5 kg
- Dimensions: 482x132x80 mm



FASTER 2448P



SG FASTER2448P - PRODUCT CODE

TECHNICAL DATA

- Controller for traditional projectors control
- 48 DMX channels in total
- 24+24 control sliders (pages A/B)
- 4 pages for 12 programs (up to 4.600 programmable steps)
- Fader setting and high speed execution
- Possibility of edit a scene live or deferred
- Music mode (internal microphone)
- Compatible MIDI IN/OUT – THRU
- External Input audio

POWER SUPPLY

- Input Voltage: DC 9V, 1000mA min
- External adapter included AC~100-240V, 50/60Hz

WEIGHT AND DIMENSIONS

- Net weight: 4,5 kg
- Dimensions : 485x290x95(h) mm

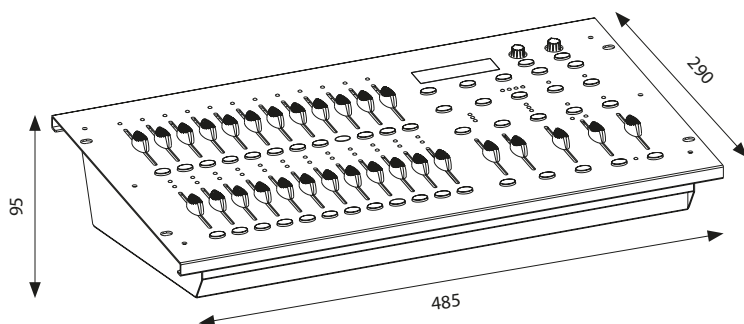

FASTER 24PB

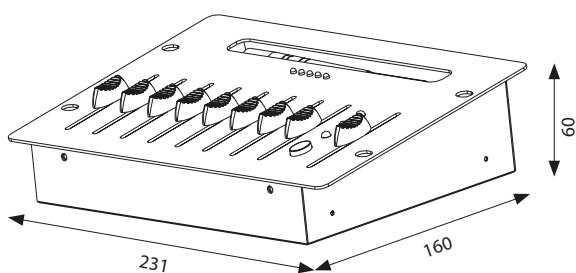

SG FASTER24PB - PRODUCT CODE

TECHNICAL DATA

- Manual controller for traditional projectors control
- 24 DMX channels in total
- 8+8+8 control sliders (pages A/B/C)
- Wireless transmitter for DMX control without cables
- Internal battery

POWER SUPPLY

- Input Voltage: AC 100-240V, 50/60 Hz
- Internal battery 7,4 VDC – 2600 mAh

WEIGHT AND DIMENSIONS

- Net weight: 1,2 kg
- Dimensions : 231x160x60(h) mm





SG FASTERSP6 - PRODUCT CODE

TECHNICAL DATA

- 1 input - 6 output DMX512
- Opto-insulated Input and Outputs signals
- 1 DMX Input XLR 3-poles
- 1 DMX Input XLR 5-poles
- 6 DMX Outputs XLR 3-poles
- 1 DMX Thru XLR 3-poles for connection to another distributor
- 1 DMX Thru XLR 5-poles for connection to another distributor
- 1 Standard rack 19" unit

POWER SUPPLY

- AC~100-240V - 50/60Hz
- Power In connection with powerCON socket

WEIGHT AND DIMENSIONS

- Net weight: 2,0 kg
- Dimensions: 480x150x50 mm

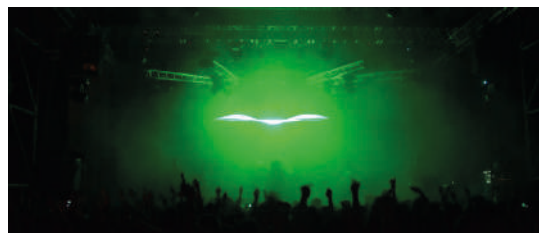
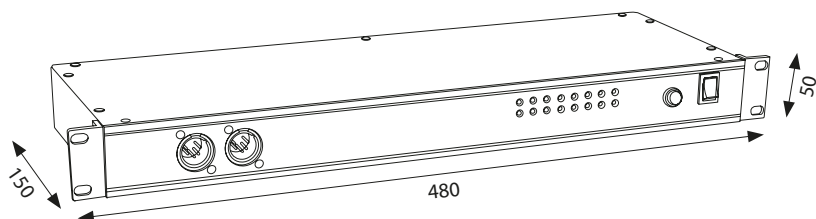

WECON STICK



SG WECONSTICK3 - PRODUCT CODE

TECHNICAL DATA

- DMX Wireless Receiver
- Range: 600 meters (line-of-sight)
- Number of channels: 512
- Operational Frequency: Frequency: 2.402 – 2.480GHz, ISM, 79 channels
- FHSS: 1100 hops / sec
- Modulation method: GFSK
- Maximum Transmit Power: 22dBm
- Receiver Sensitivity: -93dBm
- 32-bit ARM Processor, DMA transfer without delay
- 3-poles XLR In connector
- One-touch button with a Tri-color status indicator
- Groups and dmx protocols easy selection
- Integrated antenna

POWER SUPPLY

- Input voltage: 5VDC
- Max Power: 500 mA@5V DC max
- AC/DC adapter and USB charging cable included
- Battery type: 1 x lithium-ion 3.7 V, 380 mAh, 1.4 Wh
- Charge time: 50 min (90%) – 70 min (full)
- Discharge time: max 20 hrs

WEIGHT AND DIMENSIONS

- Weight: 160 g
- Dimensions: 95x18x18 mm

WECON USB PEN



SG WECONUSB - PRODUCT CODE

TECHNICAL DATA

- DMX Wireless Receiver
- Range: 600 meters (line-of-sight)
- Number of channels: 512
- Operational Frequency: Frequency: 2.402 – 2.480GHz, ISM, 79 channels
- FHSS: 1100 hops / sec
- Modulation method: GFSK
- Maximum Transmit Power: 22dBm
- Receiver Sensitivity: -93dBm
- 32-bit ARM Processor, DMA transfer without delay
- USB Type A DMX connector
- One-touch button with a Tri-color status indicator
- Groups and dmx protocols easy selection
- Integrated antenna

POWER SUPPLY

- Input voltage: 5VDC with USB Type-A
- Max Power: 350 mA@5V DC

WEIGHT AND DIMENSIONS

- Weight: 60 g
- Dimensions: 40x20x10 mm

WECON BOX IP



SG WECONBOXIP - PRODUCT CODE

TECHNICAL DATA

- DMX Wireless Transmitter/Receiver
- Range: 600 meters (line-of-sight)
- Number of channels: 512
- Operational Frequency: Frequency: 2.402 – 2.480GHz, ISM, 79 channels
- FHSS: 1100 hops / sec
- Modulation method: GFSK
- Maximum Transmit Power: 22dBm
- Receiver Sensitivity: -93dBm
- 32-bit ARM Processor, DMA transfer without delay
- One-touch button with a Tri-color status indicator
- Groups and dmx protocols easy selection

STRUCTURE AND CABINET

- Aluminium Housing
- Mounting points: 1 pairs of 1/4 turn locks
- IP rating: IP65
- XLR 3-poles DMX IN/OUT connection IP65

POWER SUPPLY

- Input Voltage: AC 100-240V, 50/60 Hz
- Switching power supply unit
- IN/OUT power connection with Power Twist TR1 sockets
- Power supply cable 1mt included

WEIGHT AND DIMENSIONS

- Weight: 930 g
- Dimensions: 120x120x75 mm



WECON BOX



SG WECONBOX - PRODUCT CODE

TECHNICAL DATA

- DMX Wireless Transmitter/Receiver
- Range: 600 meters (line-of-sight)
- Number of channels: 512
- Operational Frequency: Frequency: 2.402 – 2.480GHz, ISM, 79 channels
- FHSS: 1100 hops / sec
- Modulation method: GFSK
- Maximum Transmit Power: 22dBm
- Receiver Sensitivity: -93dBm
- 32-bit ARM Processor, DMA transfer without delay
- 3-poles XLR In/Out DMX connectors
- One-touch button with a Tri-color status indicator
- Groups and dmx protocols easy selection

POWER SUPPLY

- Input voltage: 5VDC with USB Type-C connector
- AC/DC adapter and USB charging cable included
- Max Power: 500 mA@5V DC max

WEIGHT AND DIMENSIONS

- Weight: 230 g
- Dimensions: 103x75x35 mm





AMBIENT EFFECTS

MIMETIK MEDIUM



SG MIMETIKM - PRODUCT CODE

EFFECTS

- Smoke effect

CONTROL AND PROGRAMMING

- Radio remote controller included
- Wired remote controller with built-in timer
- Heating time: 5 min
- Continue output time: 20 sec.

STRUCTURE AND CABINET

- Metal housing, black/green color
- Adjustable bracket
- Led indicator for heating and ready to smoke
- High performance pump for long-range
- External tank: 0,9 litres
- IP rating: IP20
- For best applications and correct function we recommend using Sagitter fluids

POWER SUPPLY

- Input Voltage: AC~230V, 50 Hz
- Max power: 900W @ 230VAC

WEIGHT AND DIMENSIONS

- Net weight: 4,5 kg
- Dimensions: 235x240x140 mm

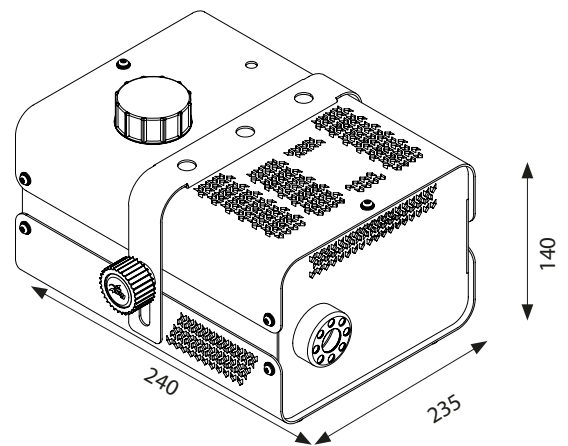

MIMETIK EXTRA LARGE



SG MIMETIKXL - PRODUCT CODE

EFFECTS

- Smoke effect

CONTROL AND PROGRAMMING

- USITT DMX 512 protocol
- Radio remote controller included
- Manual mode with specific button
- Heating time: 8 mins
- Continue output time: 10s

STRUCTURE AND CABINET

- Metal housing, black/green color
- Comfortable handle for transportation
- Red led indicator for heating and ready to smoke
- High performance pump for long-range
- External tank: 2,5 litres
- DMX 3-poles XLR In/Out connectors
- IP rating: IP20
- For best applications and correct function we recommend using Sagitter fluids

POWER SUPPLY

- Input Voltage: AC~230V 50Hz
- Max power: 1500W @ 230VAC
- Power IN connection with VDE sockets
- Power supply cable 1,5 mt included

WEIGHT AND DIMENSIONS

- Net weight: 7,3 kg
- Dimensions: 190x440x305 mm

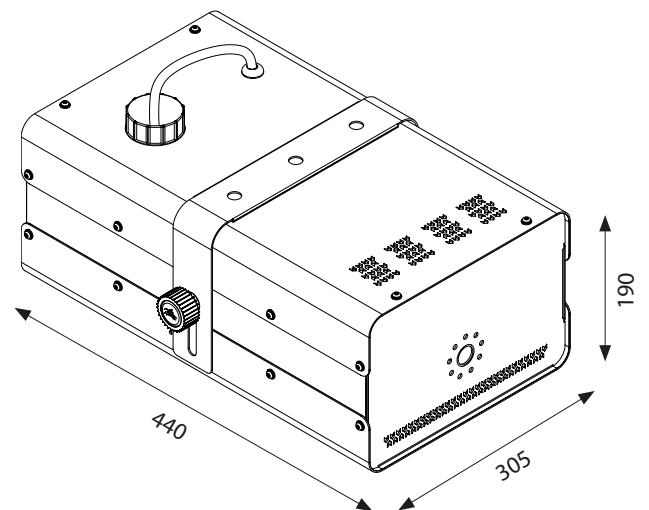



SG ARS1500FC - PRODUCT CODE

EFFECTS

- Smoke effect
- Geyser smoke effect 6 LED RGB full color

CONTROL AND PROGRAMMING

- 1 DMX configurations available: 7 channels
- Independent control smoke output and leds
- USITT DMX 512 protocol
- Radio remote controller included
- Auto mode with 7 pre-programmed colors
- Manual mode with specific button
- Automatic safety shutdown circuit for pump prevention in case of finished liquid in the circuit
- Heating time: 5 min
- Continue output time: 10 sec.

STRUCTURE AND CABINET

- Metal housing, black color
- Red LED display
- Comfortable handle for transportation
- Led indicator for heating and ready to smoke
- High performance pump for long-range smoke jet
- Auxiliary pump for instant smoke stop
- Double working mode: horizontal and vertical
- External tank: 2,5 litres
- DMX 3-5 poles XLR In/Out connectors
- IP rating: IP20
- For best applications and correct function we recommend using Sagitter fluids

POWER SUPPLY

- Input Voltage: AC~230V, 50 Hz
- Max power: 1600W @ 230VAC
- Power IN connection with VDE sockets
- Power supply cable 1mt included

WEIGHT AND DIMENSIONS

- Net weight: 8,5 kg
- Dimensions: 415x358x225 mm

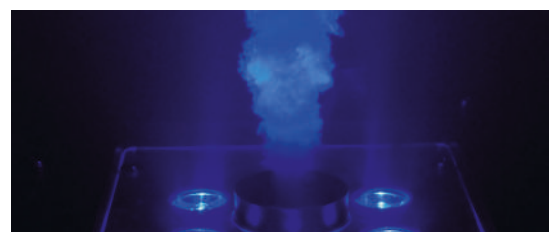
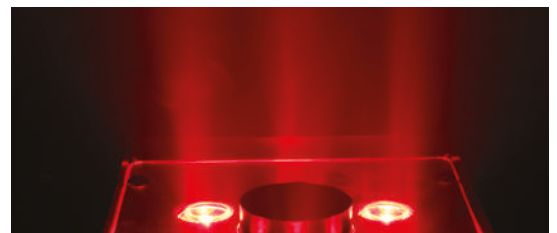
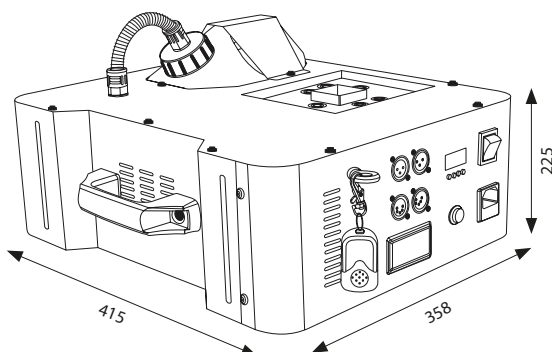

AMBIENT EFFECTS

COLOR SMOKE 900FC



SG ARS900FC - PRODUCT CODE

EFFECTS

- Smoke effect
- Geyser smoke effect 6 LED RGB full color

CONTROL AND PROGRAMMING

- 1 DMX configurations available: 7 channels
- Independent control smoke output and leds
- USITT DMX 512 protocol
- Radio remote controller included
- Auto mode with 7 pre-programmed colors
- Manual mode with specific button
- Automatic safety shutdown circuit for pump prevention in case of finished liquid in the circuit
- Heating time: 5 min
- Continue output time: 10 sec.

STRUCTURE AND CABINET

- Metal housing, black color
- Red LED display
- Comfortable handle for transportation
- Led indicator for heating and ready to smoke
- High performance pump for long-range smoke jet
- Auxiliary pump for instant smoke stop
- Double working mode: horizontal and vertical
- External tank: 2,5 litres
- DMX 3-poles XLR In/Out connectors
- IP rating: IP20
- For best applications and correct function we recommend using Sagitter fluids

POWER SUPPLY

- Input Voltage: AC~230V, 50 Hz
- Max power: 950wW @ 230VAC
- Power IN connection with VDE sockets
- Power supply cable 1mt included

WEIGHT AND DIMENSIONS

- Net weight: 7 kg
- Dimensions: 408x264x192 mm

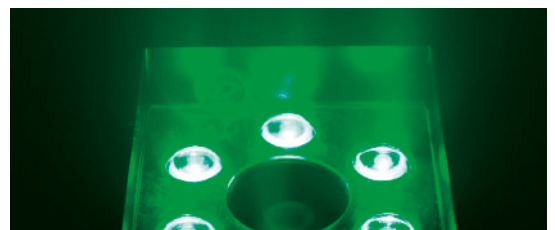
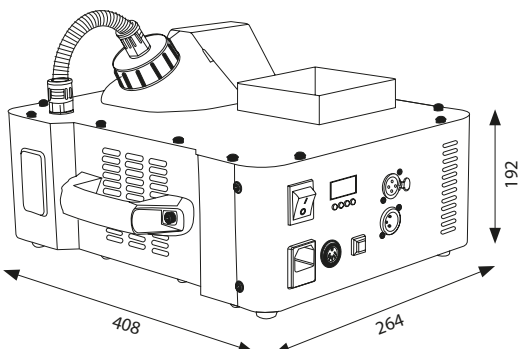



SG ARS900DJ - PRODUCT CODE

EFFECTS

- Smoke effect
- Geyser smoke effect 3 LED RGB full color

CONTROL AND PROGRAMMING

- Radio remote controller included
- Static color mode: 7 built-in colors
- Auto mode: 1 built-in color change program
- Manual mode with specific button
- Heating time: 8 min
- Continue output time: 10 sec.

STRUCTURE AND CABINET

- Metal housing, black color
- Comfortable handle for transportation
- Led indicator for heating and ready to smoke
- High performance pump for long-range smoke jet
- Double working mode: horizontal and vertical
- External tank: 0,25 litres
- IP rating: IP20
- For best applications and correct function we recommend using Sagitter fluids

POWER SUPPLY

- Input Voltage: AC~230V, 50 Hz
- Max power: 900W @ 230VAC
- Power IN connection with VDE sockets
- Power supply cable 1mt included

WEIGHT AND DIMENSIONS

- Net weight: 3,5 kg
- Dimensions: 280x245x140 mm

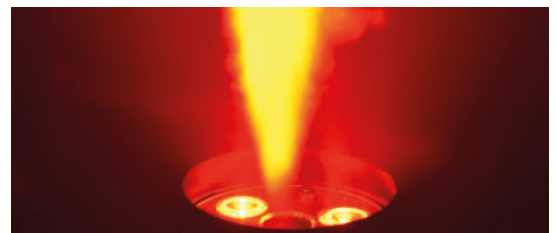
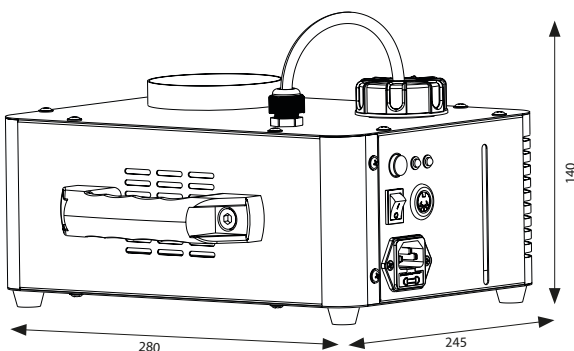



genuine
ACCESSORIES



LIGHT

Light version, suitable for small environments and 'occasional' users who want to get a nice smoke effect minimizing the expenses. This version can also be used for those who need a fast fading effect. 5 liters tank.

SG SMKFLD5L - PRODUCT CODE

MEDIUM

Version that provides an adequate coverage and durability for any kind of show, suitable for any location, i.e. live events, theaters and nightclubs. 5 liters tank.

SG SMKFLD5M - PRODUCT CODE

HIGH DENSITY

Condensed version which guarantees a long durability and an adequate coverage for a professional and covering smoke effect. 5 liters tank

SG SMKFLD5D - PRODUCT CODE



HAZER

Condensed version which guarantees a long durability and an adequate coverage for a professional and covering smoke effect. 5 liters tank.

SG HZRFLD5 - PRODUCT CODE



QUICK DISSIPATION

Quick dissipation version, this liquid guarantees intensity and fading similar to a CO2 gas effect. 5 liter tank.

SG SMKFLD5QD - PRODUCT CODE

CLAMPS AND SAFETY ROPES



SG AL290D - SG AL290DBK

Double aliscraf hook aluminum
Fit pipes from 48 mm to 51 mm
(Max Load: 100 Kg)



SG AL295D - SG AL295DBK

Double aliscraf hook aluminum
Fit pipes from 48 mm to 51 mm
(Max Load: 280 Kg)



SG AL290 - SG AL290BK

Aliscraf single hook aluminum
M10 x 50 bolt with lock nut
Fit pipes from 48 mm to 51 mm
(Max Load: 100 Kg)



SG AL295 - SG AL295BK

Aliscraf single hook aluminum
M10 x 50 bolt with lock nut
Fit pipes from 48 mm to 51 mm
(Max Load: 300 Kg)



SG CL250BK

Black extruded aluminium trigger clamp
Fit pipes from 48 mm to 51 mm
(Max Load: 250 Kg)



CL50BK

Black extruded aluminium trigger clamp
Fit pipes from 48 mm to 51 mm
(Max Load: 50 Kg)



SG CL10N - SG CL10NBK

C hook galvanized steel
Fit pipes from 35 mm to 50 mm
(Max Load: 50 Kg)



SG PLH232

Safety rope
Stainless steel rope 3.2 mm with safety carabiner
Length: 850 mm



PLH248

Safety rope
Stainless steel rope 4.8 mm with safety carabiner
Length: 850 mm

DMX CABLES



DMX CABLE 3 - poles

Professional DMX 512 cable with SEETRONIC connectors XLR 3-poles.
Cable color: Black

- SG DMX3CLU02 - 2 mt.
- SG DMX3CLU03 - 3 mt.
- SG DMX3CLU05 - 5 mt.
- SG DMX3CLU010 - 10 mt.



DMX CABLE 5 - poles

Professional DMX 512 cable with SEETRONIC connectors XLR 5-poles.
Cable color: Black

- SG DMX5CLU02 - 2 mt.
- SG DMX5CLU03 - 3 mt.
- SG DMX5CLU05 - 5 mt.
- SG DMX5CLU010 - 10 mt.



FLIGHTCASES

SG CASEJWASH400	FLIGHTCASE FOR 2 JWASH 400
SG CASEJBEAM230	FLIGHTCASE FOR 2 JBEAM 230
SG JTUBEX1BAG	PPCASE FOR 8 JTUBE X1 WITH RECHARGE
SG CASEJBAR8BAT	CASE FOR 6 LED BAR WITH RECHARGE
SG CASEQPIXBAR	QPIX BAR CASE FOR 16 LED BARS
SG CASEPIXI5	FLIGHTCASE FOR 6 PIXI 5





SG SDJCAT24IE

www.sdjlighting.com



**ENJOY
YOUR
LIGHTING**

SDJ

is a brand of

PROEL SPA

(Worldwide Headquarters)

Via alla Ruenia, 37/43

64027 Sant'Omero (TE) - ITALY

Tel. +39 0861 81241

Fax +39 0861 887862

P.I. 00778590679

N.Reg.AEE IT 08020000002762

sdjlighting.com